



INDUSTRIAL WASHING MACHINES

SAN100e Sanitising Machine

10 standard models to suit every application and budget

A freestanding sanitiser unit designed to accommodate buckets, bins, plastic bags, tubs, tins and trays up to a maximum size of 450 mm wide by 450 mm high. The machine is designed for low (goods inward) to high-care (production) operation.



Benefits:

- > Newly designed removable top canopy cover enables ease of maintenance with access to all components
- > Hygienic design complies with all UK and EU standards, and all are CE assessed and certified
- > Cost efficient, dependable and effective sanitisation
- > Designed for low - to high-care operation
- > Fully assembled and tested prior to dispatch

www.indwash.co.uk





STANDARD FEATURES

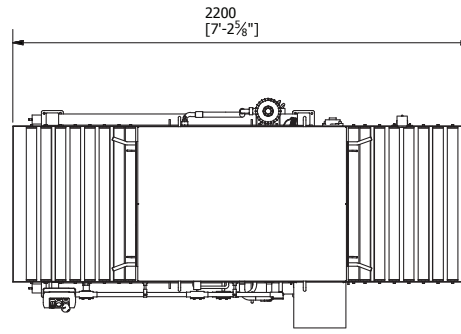
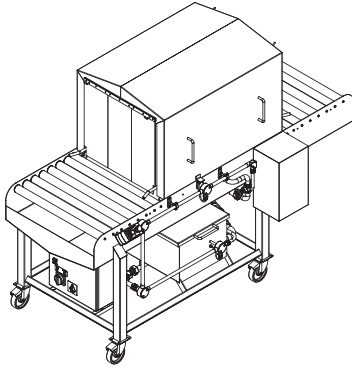

dimensions are approximate only

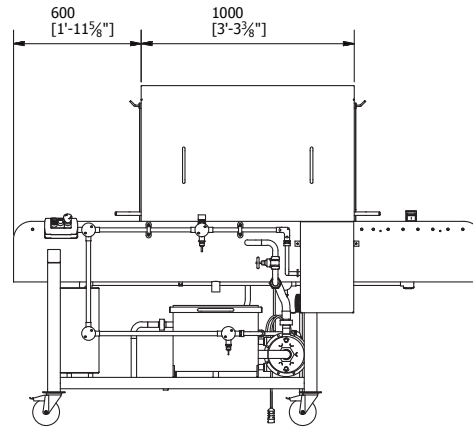
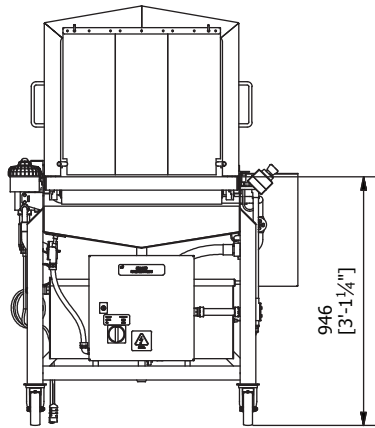

- > Stainless steel T304/316 construction
- > 4 mm thick PVC curtains
- > 66% open area Polypropylene food grade belt for total product saturation and improved hygiene
- > High temperature polymer or stainless steel jetting system
- > Castors for ease of positioning, cleaning and maintenance procedures
- > Left or right handed versions
- > Electronic water level control with built in low level protection for pumps and heating systems (where applicable)
- > Stainless steel control panel to IP66 standard complete with CAT IV 24V DC control and safety circuits
- > 'Magic eye' at end of conveyor to halt product if not removed
- > Stainless steel pump, filters and jet system
- > Fresh water, total loss spray system or recirculation option via stainless steel holding tank
- > Sustained 360 ° product misting with water and automatically dosed chemical sanitizer via solenoid controlled Dosotron proportional injector pump
- > Variable speed conveyor drive – 1-5 metres per minute recommended for optimum sanitizer contact time

Options:

Lockable detergent cage
Knock out/load table
Part roller/part conveyor to suit layout/
operational requirements

Total loss or recirculated systems available,
usually from stock
Upgraded filter options for micro particulates
Flexible, tailored service contracts

www.indwash.co.uk

Delivery: Typically 2-3 weeks, subject to production commitments at time of order

Industrial Washing Machines Ltd, Facet Road, Kings Norton, Birmingham, B38 9PT, UK

T: +44 (0) 121 459 9511 F: +44 (0) 121 451 3241 E: info@indwash.co.uk